

## Waste & Storage Bins

## Crane Bins

### Type NCB Crane Bin

A stackable bin designed for crane lifting and emptying. The stack legs allow for easy handling by forklift. Available in either painted or galvanised finish.

- Safe Working Load: 1000 kg

#### Available Options

- Cast Iron or Rubber Wheels
- Drain holes
- Fork pockets

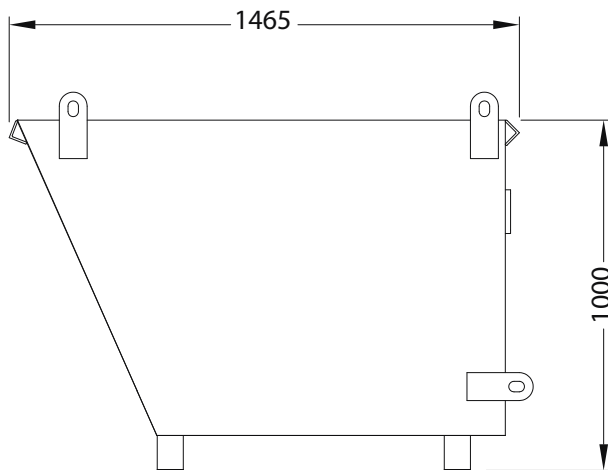

NCB 9

Type	Capacity (cu. m)	Width (mm)	Unit Weight (kg)
NCB 6	0.7	600	160
NCB 9	1.0	900	180
NCB 12	1.35	1200	190

### Type CPB 6 Crane Bin

A compact, heavy duty stackable bin ideal in machine shops and foundries for component storage. Manufactured from 3mm plate and fitted with crane lugs, these bins are easily moved by forklift or crane. Available in either painted or galvanised finish.

- Capacity: 0.23 cubic metres
- Safe Working Load: 1000 kg
- Unit Weight: 80 kg

#### Available Options

- Cast Iron or Rubber Wheels



CPB 6 Stacked

