

Type DB-H Hydraulic Bucket

A slip-on hydraulically operated bucket which quickly connects to the forklift, requiring one additional hydraulic function to operate.

The hydraulic operation allows for full backwards tilt making the bucket suitable for liquid products. Bucket is fitted with a hardened steel wear edge. Available in either painted or galvanised finish.

- Volume Capacity: 0.22 cu m
- Safe Working Load: 500 kg
- Bucket Width: 1200 mm
- Fork Pocket size: 165 mm x 65 mm
- Fork Pocket Centres: 635 mm
- Unit Weight: 200 kg

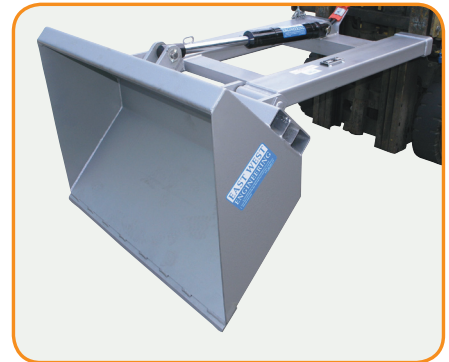
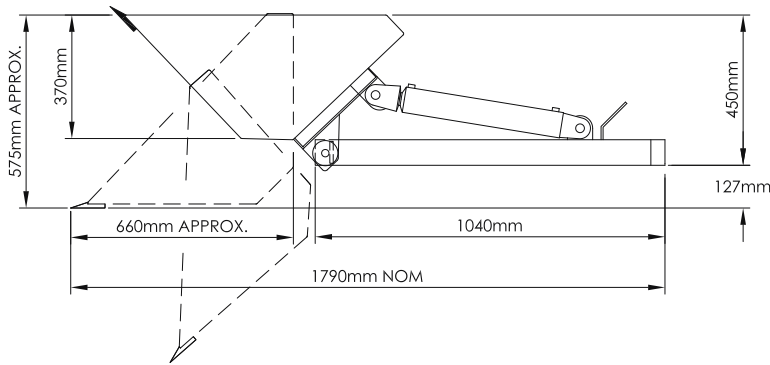

Type DB-M Manual Bucket

This manually operated slip-on dirt bucket connects quickly to the forklift without any hydraulic connection required. Extremely useful for removing loose material from floors such as gravel, grain, coal etc. Dumping of product is via a simple mechanical lever operated from the drivers seat. Bucket is fitted with a hardened steel wear edge. Available in either painted or galvanised finish.

- Volume Capacity: 0.22 cu m
- Safe Working Load: 500 kg
- Bucket Width: 1200 mm
- Fork Pocket Size: 165 mm x 65 mm
- Fork Pocket Centres: 635 mm
- Unit Weight: 195 kg

