

## Type FBT-SH Bin Tipper

The FBT-SH Forward Bin Tipper is ideal for handling and emptying bins in agricultural and manufacturing industries. This slip-on attachment requires only one hydraulic function.

A purpose built hydraulic sequencing valve eliminates the potential to drop the bin as rotation will not commence until the bin is secured into position, while the gentle action of the clamp arms prevents damage to the bins. The standard FBT-SH will suit bins up to 1200mm square, with a height range of 675 to 925mm. Enamel paint finish.

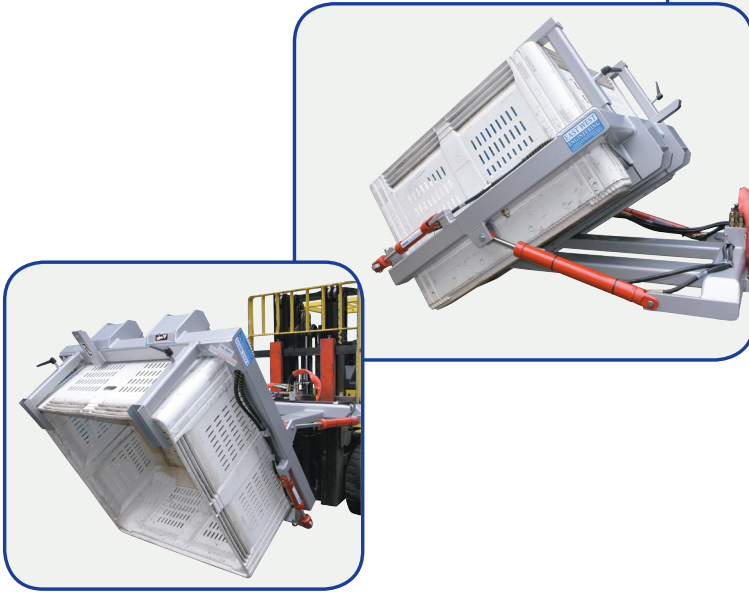
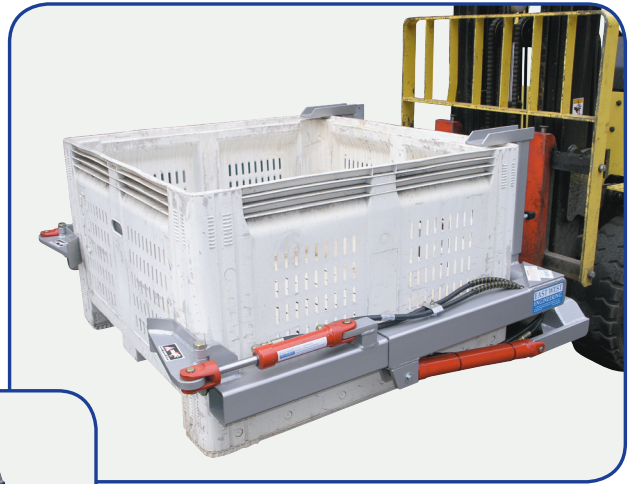

- Safe Working Load: 1000 kg
- Unit Weight: 290 kg
- Load Centre: 880 mm
- Lost Load: 300 mm
- Fork Pocket Size: 155 mm x 55 mm
- Fork Pocket Centres: 540 mm

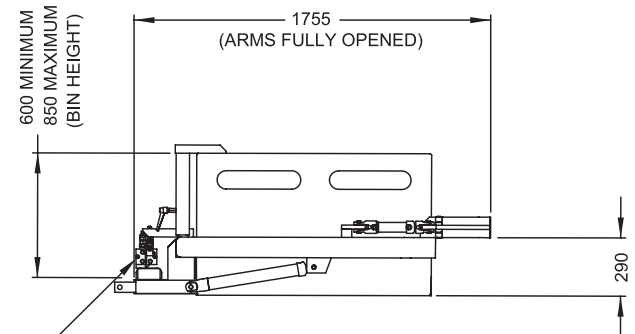
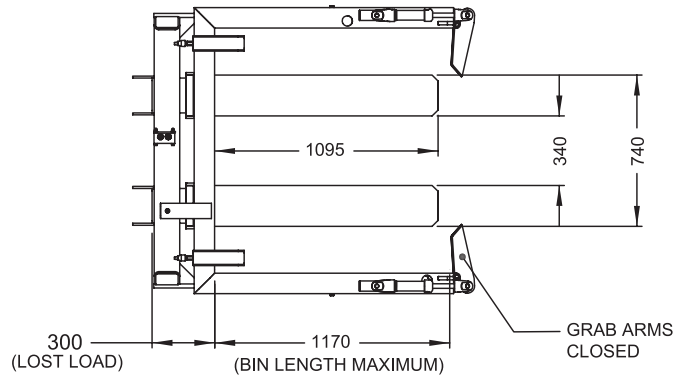
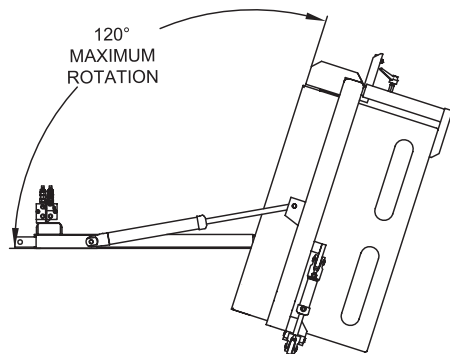
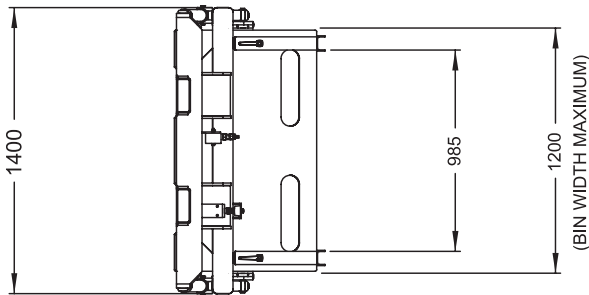

DUAL CYLINDER SEQUENCING MANIFOLD